



LP-16s Manual

AMARI Audio equipment co.,LTD

www.amari.cc

Email: amari@vip.163.com

Preface



Thank you very much for purchasing Armani vinyl record player products.

Please read this manual carefully before use.



Save all packaging materials. The player can only be moved or transported using the original packing. Not using the original packing with increased risk of damage during transportation.



Do not open the motor cover. In order to avoid electric shock and damage the record player.

Do not pour water on the player or leave it in an excessively humid environment.

Packing List

Aluminium Platter	1	Record Mat	1
Vinyl Protractor Disc	1	Record Clamp	1
Bearing	1	Power Supply	2
Belt	1	Tonearm Cable	1 integrated with Tonearm
Tonearm Counterweight	1	Bearing Oil	1 Tube
Stylus Tracking Force Gauge	1	Alley Key	1
Additional Tonearm Counterweight	1		

LP-16s Record Player



Additional tonearm counterweight suitable for cartridge heavier than 6 grams.



Installation Procedure

1. Place the turntable base on a horizontal table or platform, use a level ruler to check and adjust the turntable feet such that the base is level. After adjusting, lock it with a nut to maintain the level.

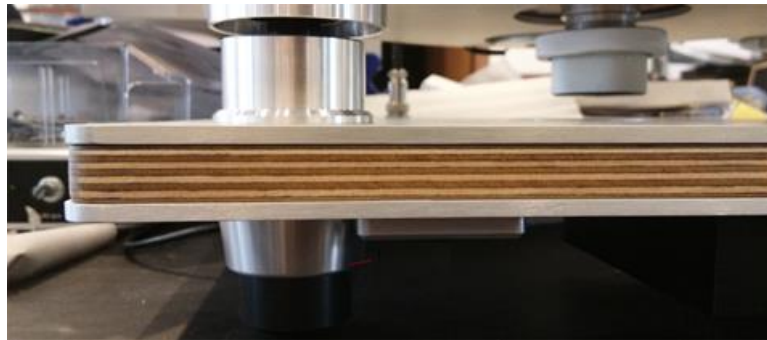

2. Remove the protective plug of the bearing sleeve and use the supplied syringe to inject a small amount of lubricant into the lower sleeve of the shaft (the lower sleeve is filled with oil at the factory). Then place the bearing shaft vertically into the lower sleeve and let it sink in naturally. (note that you must insert vertically and careful to avoid damage to the shaft, also do not push the bearing hard against the bearing sleeve)

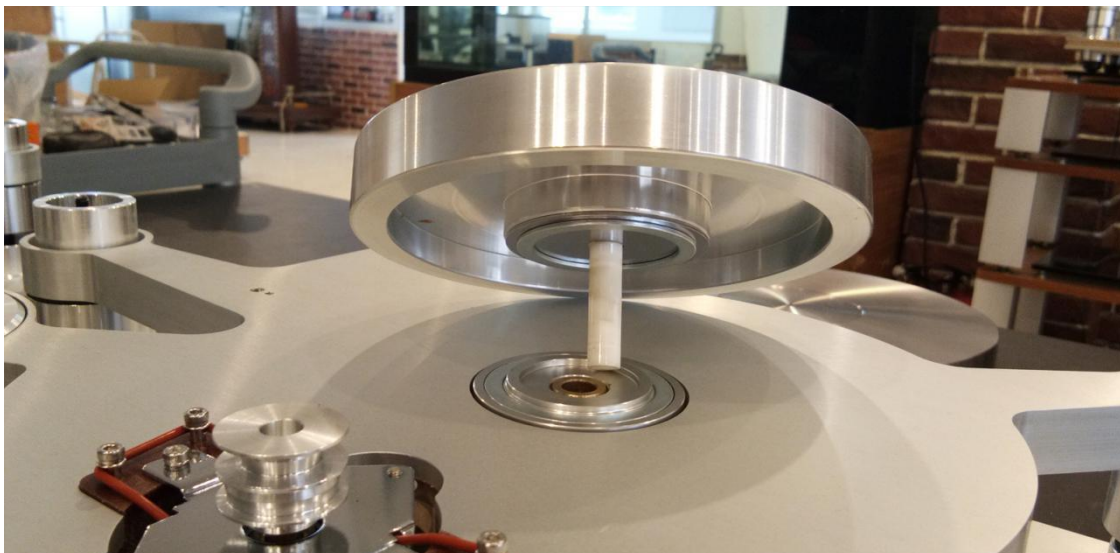

LP-16s Record Player

3. Put the belt on the motor wheel and aluminum inner platter.

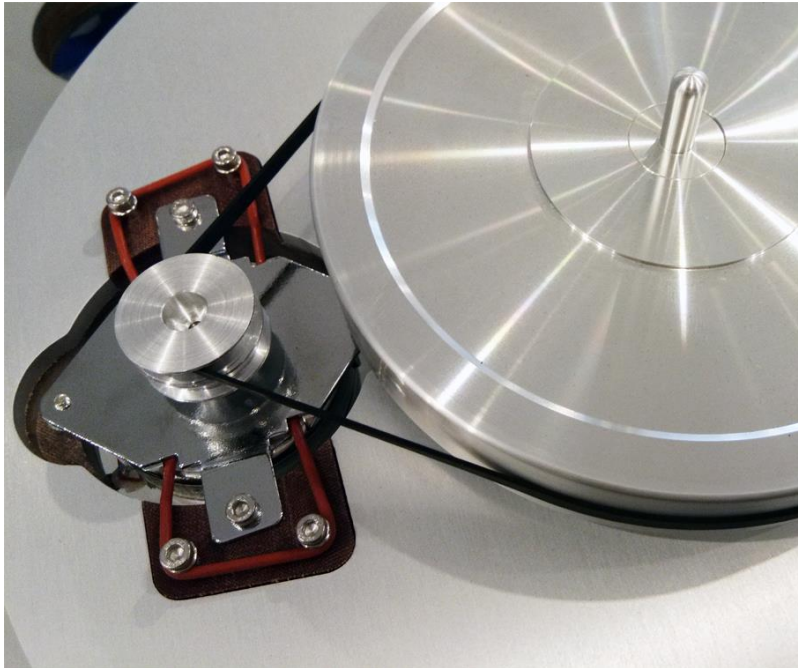

4. Put the aluminum alloy outer platter on top of the inner platter and ensure the hole of the outer platter is align with the shaft.

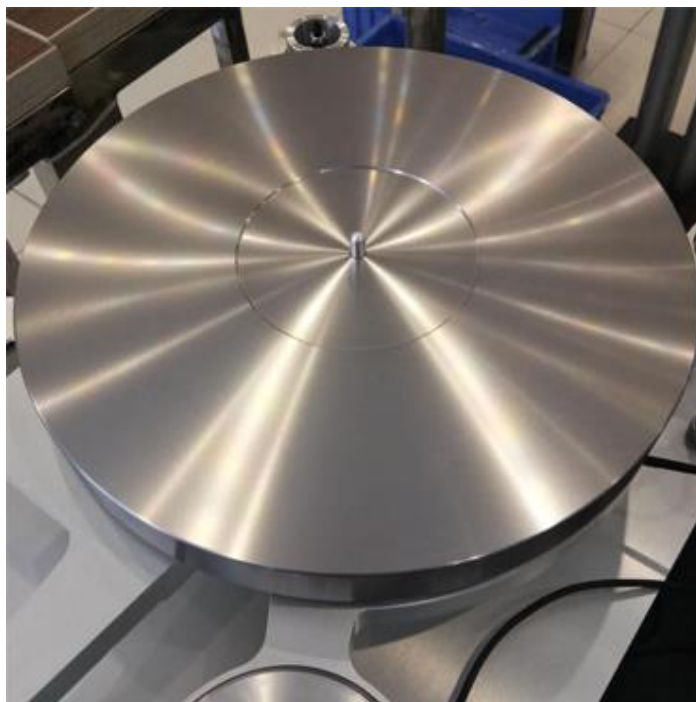

LP-16s Record Player

5. Attach the tonearm counterweight to the rear axle end of the phono arm, and adjust the height of the end of the tonearm by turning the VTA adjustment screw, so the tonearm is parallel to the surface of the record. Lock the tonearm in place by tightening the base collar screw.

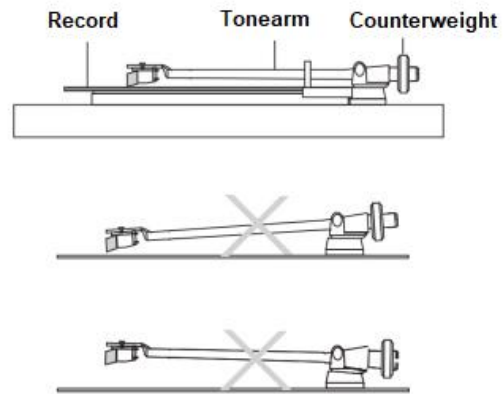
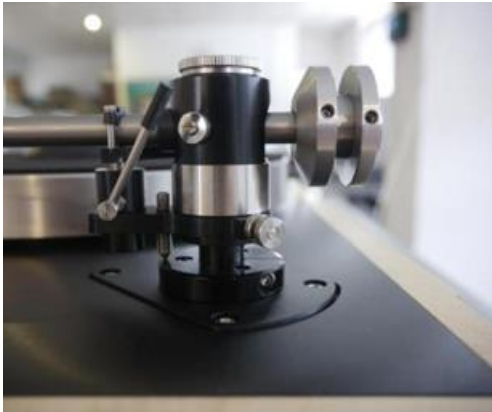

LP-16s Record Player

Components

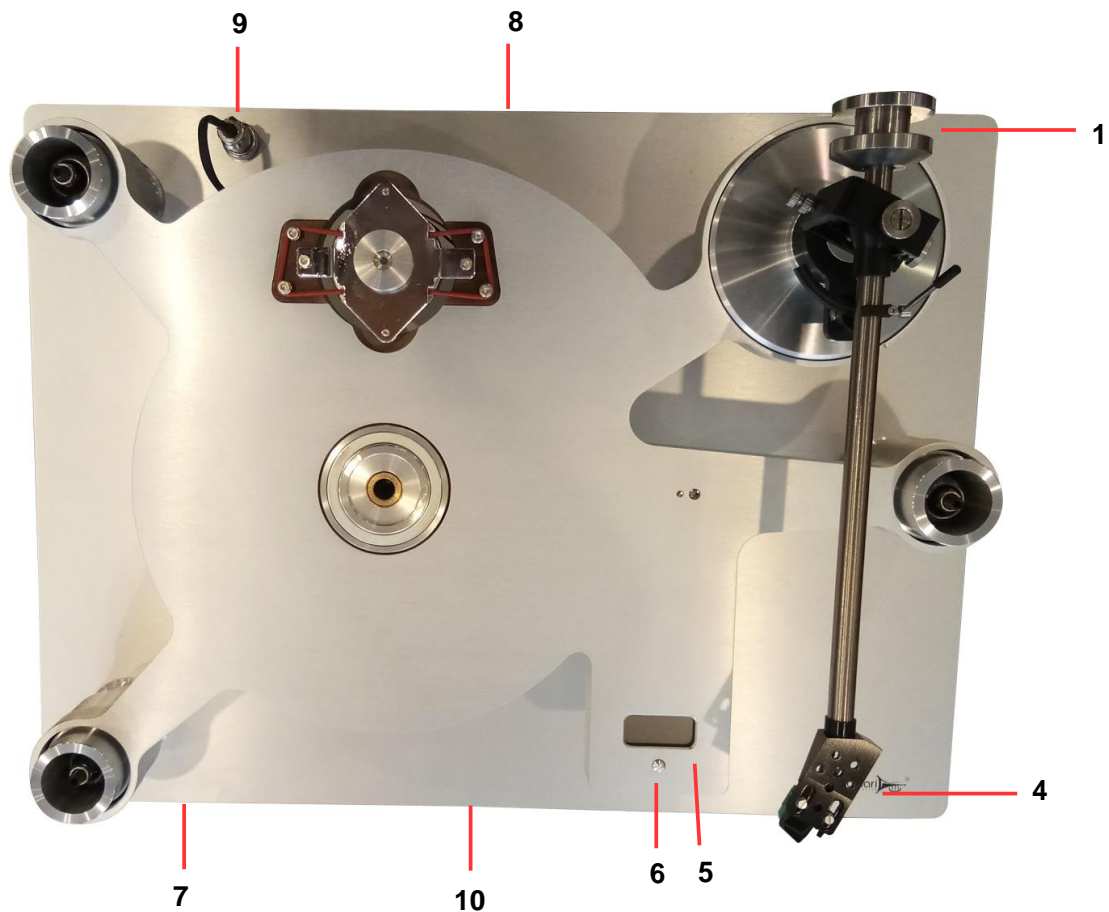

1. Counterweight – for tracking force adjustment
2. VTA adjustment screw
3. Anti-skate adjustment screw
4. Cartridge
5. Real time speed monitoring
6. Real time speed monitoring switch
7. On/Off switch (beneath the plinth)
8. Phono amplifier (beneath the plinth)
9. Turntable Power Socket (24V behind the plinth)
10. Motor Speed Controller (beneath the plinth)
11. Tonearm lifter
12. Tonearm lock screw
13. Tonearm base collar screw

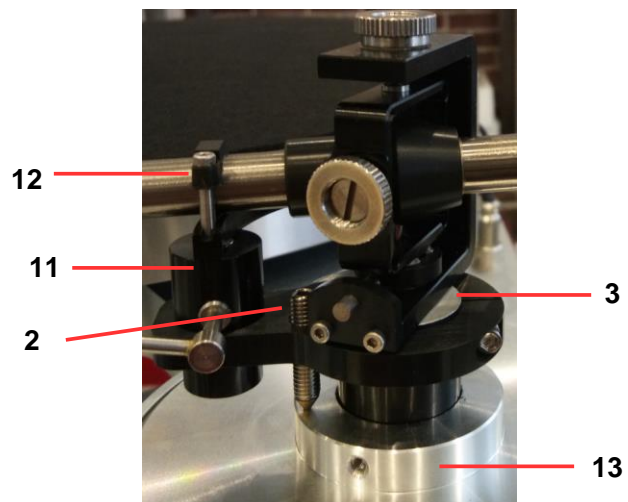

- * The overhang was adjusted at the factory, just adjust it if you change the tonearm.
- * The 3 feet at the bottom of the base plinth, can be used to adjust the levelling
- * When the phono amplifier power supply is connected, it will not be turned off until the power is disconnected.

LP-16s Record Player



1. Motor start/stop switch
2. Switch between 33/45 rpm
3. Fine adjustment of 33rpm
4. Fine adjustment of 45rpm



- 1
- 2
- 3
- 4
- 5

1. Phono amplifier power input (DC24V*)
2. Phono amplifier output
3. MM/MC switch
4. Phono amplifier input
5. Phono amplifier ground

* In certain market, 18VAC power supply is included instead of 24VDC

Adjust levelling of upper plinth

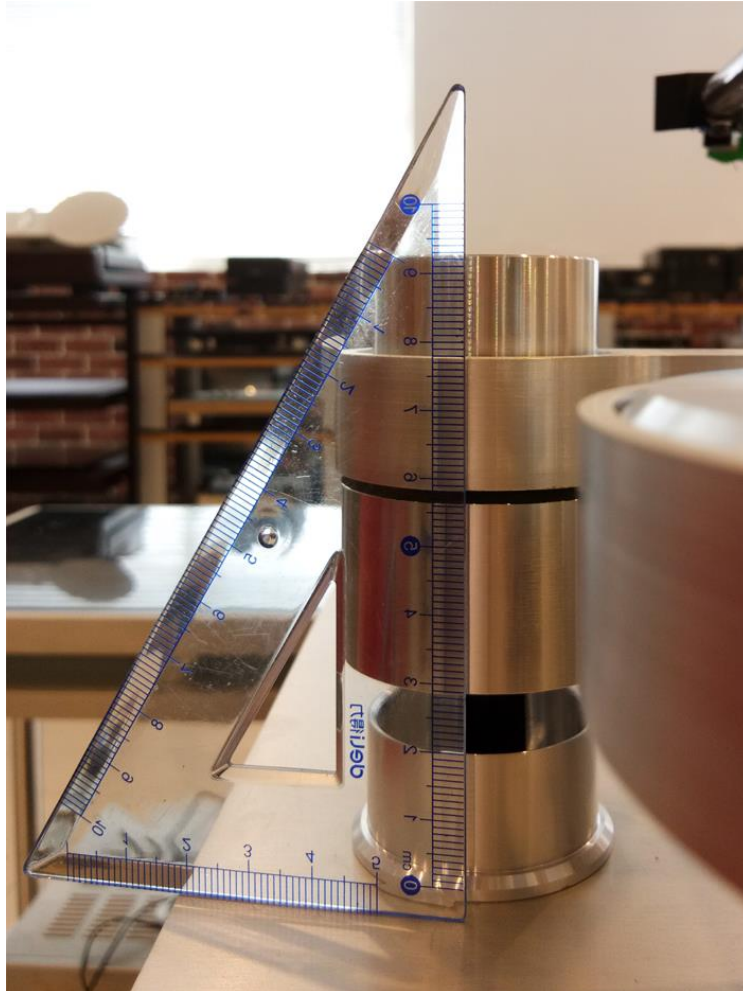

LP-16s Record Player



Adjustment and playback

1. Connect the turntable motor power supply (DC24V) and the phono amplifier power supply (DC24V or AC18V). Connect the audio output of the tonearm to the input of the phono amplifier. The pickup selector switch to the MM type (for standard AT-95E cartridge), and the output of the phono amplifier to the inputs of pre-amplifier or integrated amplifier. During connection, please ensure all amplifier are power off. Turn the speed controller power on, the 33.3rpm indicator on the panel will light up, the turntable will start to rotate, press the speedometer display button, the exact value of the real-time speed will appear on the display. Adjust the fine-tuning knob on the speed controller to the appropriate speed according to the record requirements. Repeat the adjustment for 45rpm. Please note that for playing 45rpm records, start the motor in 33rpm mode first, and then switch to 45rpm mode afterwards, please do not start in 45rpm mode directly.
- 2a. VTA adjustment: put the stylus on a stationary platter, and adjust the VTA adjustment screw until the tonearm is parallel with the platter.
- b. Stylus tracking force adjustment: put the stylus tracking force gauge on the stationary turntable, adjust the front and rear position of the counterweight, so that the reading meets the tracking force specification of the cartridge. 2.0g is recommended for standard AT-95E cartridge.
- c. Adjust Zenith angle: with Amari's unique protractor disc, the stylus should be in line with the lines on the disc when the tip of the stylus is resting on the null points. Loosen the cartridge mounting screws, adjust the position of the cartridge and then tightening the mounting screws. Do not over-tighten the mounting screws as this may damage the phono cartridge.

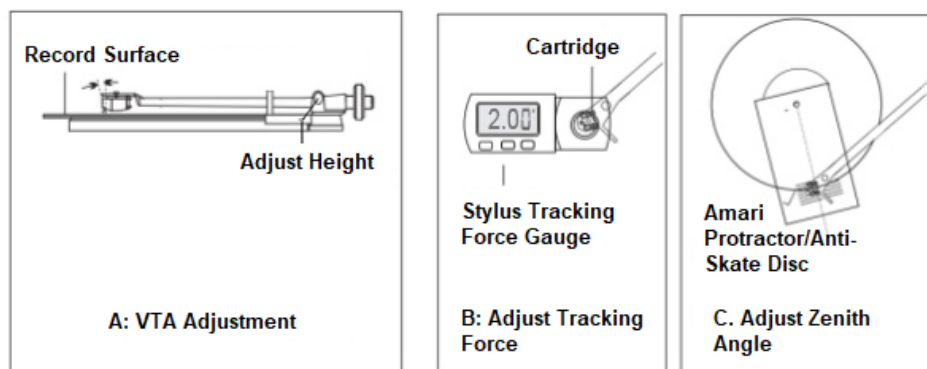

3. When the above adjustment is completed, put on the record, turn on the power of the turntable, lift the arm lift lever, move the pickup to the place where you want to start playing, slowly lower the lifter by about 20°, so that the tonearm follows the bracket and slowly lowers the stylus onto the record. At this point, you can concentrate on the music that Amari brings to you.

LP-16s Record Player



About LP-16s

The plinth

- (1) 24mm thick aluminum/wood sandwich based plinth which has good vibration absorption.
- (2) The bearing, motor, tonearm all fixed on 24mm thick aluminum plinth, which is suspended by 3 springs.

Magnetic levitated bearing system

- (1) Use the Neodymium Iron Boron magnet to float the bearing shaft. Adjust the lower sleeve so platter has about 1000 grams of force to press against the steel ball.
- (2) Seal oil well in the lower sleeve in order to form an oil pool around the steel ball. The steel ball and the ceramic shaft are submerged inside the oil pool, so an oil film is formed on the ceramic bearing shaft. Therefore the bearing rotation is smooth, and without noise.
- (3) Bearing shaft is made of zirconia ceramics which is smooth, hard and wear-resistant.
- (4) Lower sleeve is made of copper is covered with an oil-containing copper sleeve, and special powder is sintered with copper.
- (5) The magnetic levitated bearing uses a magnetic leakage prevention mechanism to prevent magnetic leakage.
- (6) The pressure of the steel ball can be adjusted by the large nut of the lower sleeve, so that the sound can be adjusted.

Motor

- (1) Special synchronous single-phase 12-volt motor, 3w. The speed is stable, the noise is low, and the vibration is small.
- (2) Motor mechanism is mounted by an O-rings to reduce motor vibration to be transmitted to the

Speed Adjustment

33 1/3, 45 rpm speed controlled by electronic speed controller, and speed can be fine-tuned respectively.

Speed Monitoring

Accurate real-time infrared speed monitoring.

Feet

- (1) Three feet design for full adjustability and leveling capability.
- (2) The POM feet have excellent shock absorption.

MM/MC Phono Amplifier

Switchable MM and MC phono amplifier.

Tonearm and Cartridge

Single point 9 inches tonearm and Audio Technica original AT-95E MM cartridge fitted as standard

Accessories

- (1) Additional tonearm counterweight
- (2) Record strobe disc
- (3) Record clamp
- (4) Stylus tracking force gauge
- (5) Bearing oil in syringe
- (6) 24V DC Power Supply
- (7) 24V DC (18V is fitted in some markets) Power Supply

Specifications

- (1) Net weight: 14kg
- (2) Dimensions: 495x360x170mm
- (3) Platter weight: 2.6kg
- (4) Pivot to spindle distance: 222mm
- (5) Overhang: 17.3mm
- (6) Tonearm effective length: 239.3mm
- (7) AT-95E tracking force: 1.5g-2.5g
- (8) Power supply: AC100-240V 50/60Hz 650mA
- (9) Phono Amplifier Input Impedance: MC 200 Ohms, MM 47K Ohms