



LP-18s Manual

AMARI Audio equipment co.,LTD

www.amari.cc

Email: amari@vip.163.com

Preface



Thank you very much for purchasing Armani vinyl record player products.

Please read this manual carefully before use.



Save all packaging materials. The player can only be moved or transported using the original packing. Not using the original packing with increased risk of damage during transportation.



Do not open the motor cover. In order to avoid electric shock and damage the record player.

Do not pour water on the player or leave it in an excessively humid environment.

Packing List

Aluminium Platter	1	Record Mat	1
Vinyl Protractor Disc	1	Record Clamp	1
Bearing	1	Power Supply	2
Belt	1	Tonearm Cable	1 integrated with Tonearm
Tonearm Counterweight	1	Bearing Oil	1 Tube
Stylus Tracking Force Gauge	1	Alley Key	1
Additional Tonearm Counterweight	1		

LP-18s Record Player



Additional tonearm counterweight suitable for cartridge heavier than 6 grams.



Installation Procedure

1. Place the turntable base on a horizontal table or platform, use a level ruler to check and adjust the turntable feet such that the base is level. After adjusting, lock the locking collar to maintain the level.



2. Remove the protective plug of the bearing sleeve and use the supplied syringe to inject a small amount of lubricant into the lower sleeve of the shaft (the lower sleeve is filled with oil at the factory). Then place the bearing shaft vertically into the lower sleeve and let it sink in naturally. (note that you must insert vertically and careful to avoid damage to the shaft, also do not push the bearing hard against the bearing sleeve)

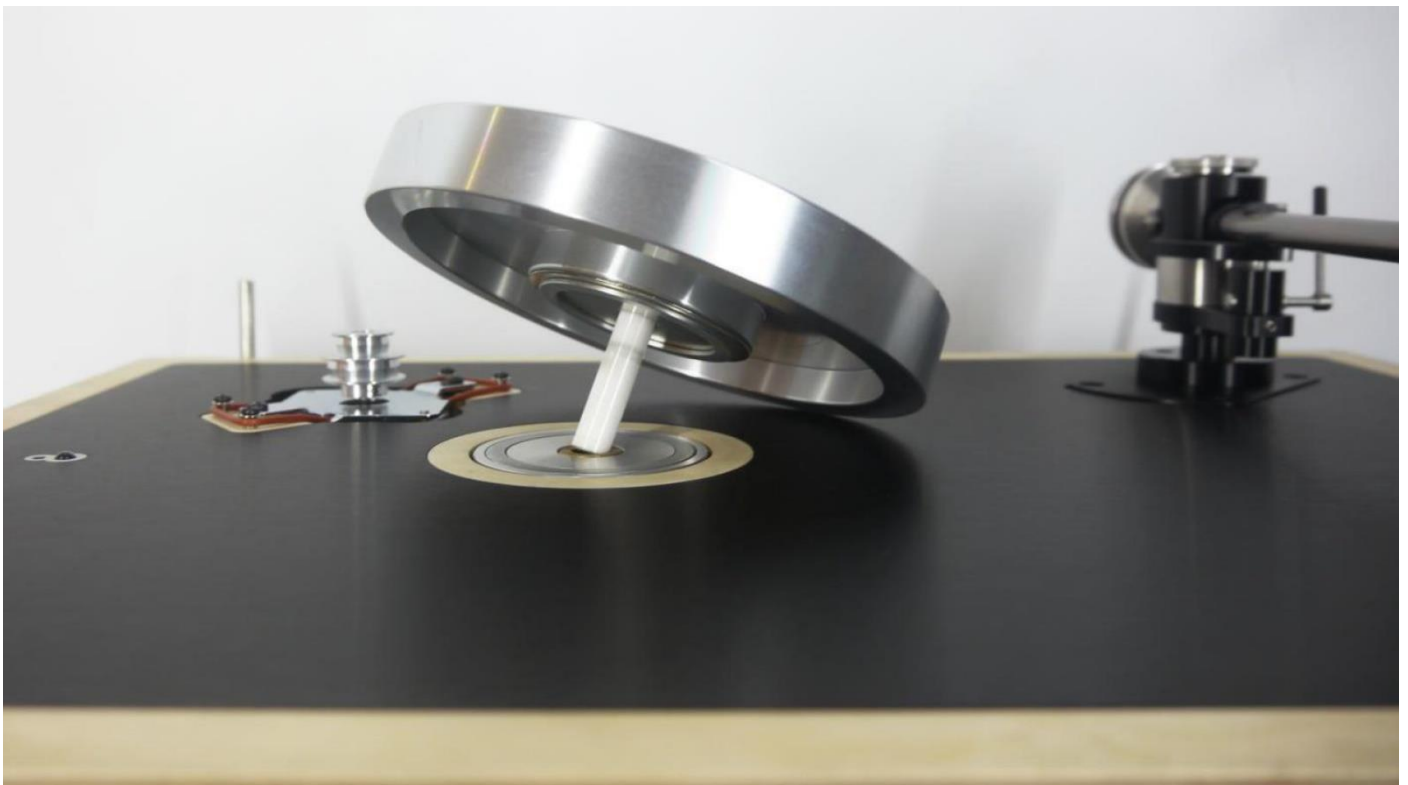

LP-18s Record Player

3. Put the belt on the motor wheel and aluminum inner platter.



4. Put the aluminum alloy outer platter on top of the inner platter and ensure the hole of the outer platter is align with the shaft.



LP-18s Record Player



5. Attach the tonearm counterweight to the rear axle end of the phono arm, and adjust the height of the end of the tonearm by turning the VTA adjustment screw, so the tonearm is parallel to the surface of the record. Lock the tonearm in place by tightening the base collar screw.

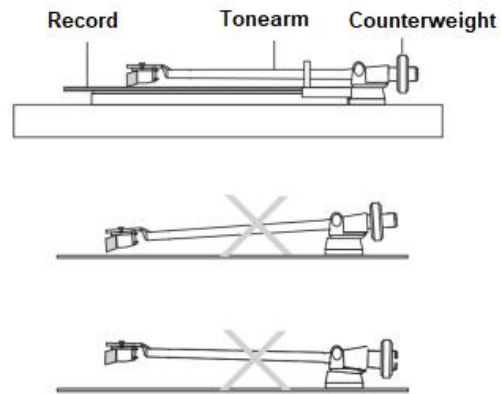
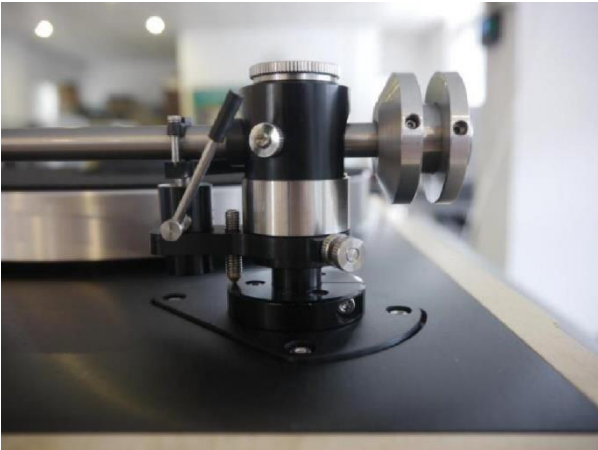

6. Align the two small holes on the dust cover with the steel bars on the back of the turntable base install the dust cover gently.



LP-18s Record Player



Components

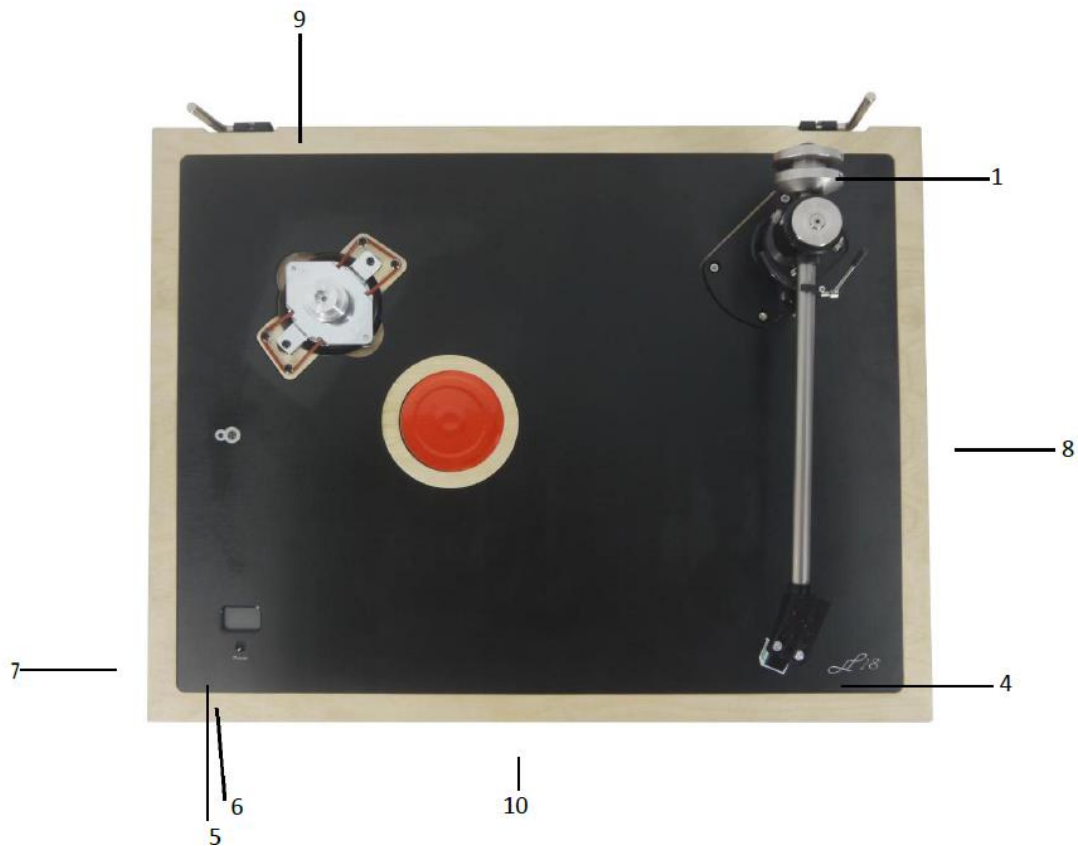

1. Counterweight – for tracking force adjustment
2. VTA adjustment screw
3. Anti-skate adjustment screw
4. Cartridge
5. Real time RPM display
6. Real time RPM display on/off
7. Turntable On/Off switch (beneath the plinth)
8. Phono amplifier (beneath the plinth)
9. Turntable power supply connector 24V DC (back of plinth)
10. Motor Speed Controller (beneath the front of the plinth)
11. Tonearm lifter
12. Tonearm base collar screw
13. Tonearm lock screw

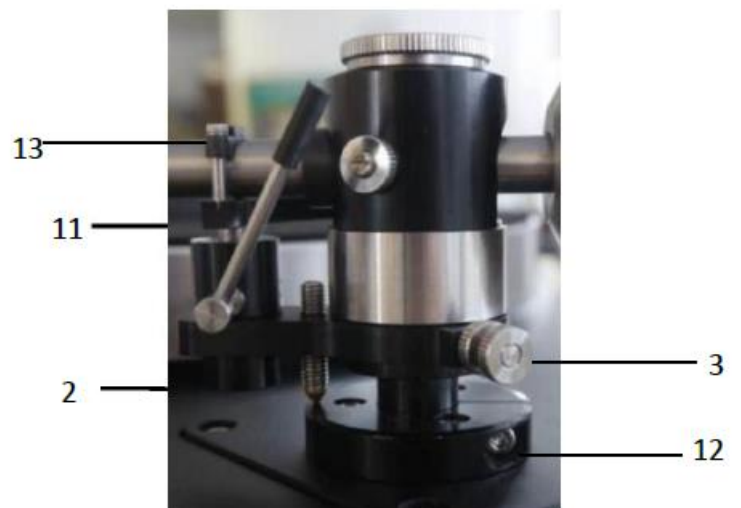

- * The overhang was adjusted at the factory, just adjust it if you change the tonearm.
- * The 3 feet underneath the plinth is used to adjust the height and level of the plinth.
- * When the phono amplifier power supply is connected, it will not be turned off until the power is disconnected.

LP-18s Record Player



1. Support foot lock collar
2. Motor start/stop switch
3. Switch between 33.3/45rpm (The corresponding green LED will turn on)
4. Speed adjustment for 33.3 rpm
5. Speed adjustment for 45 rpm

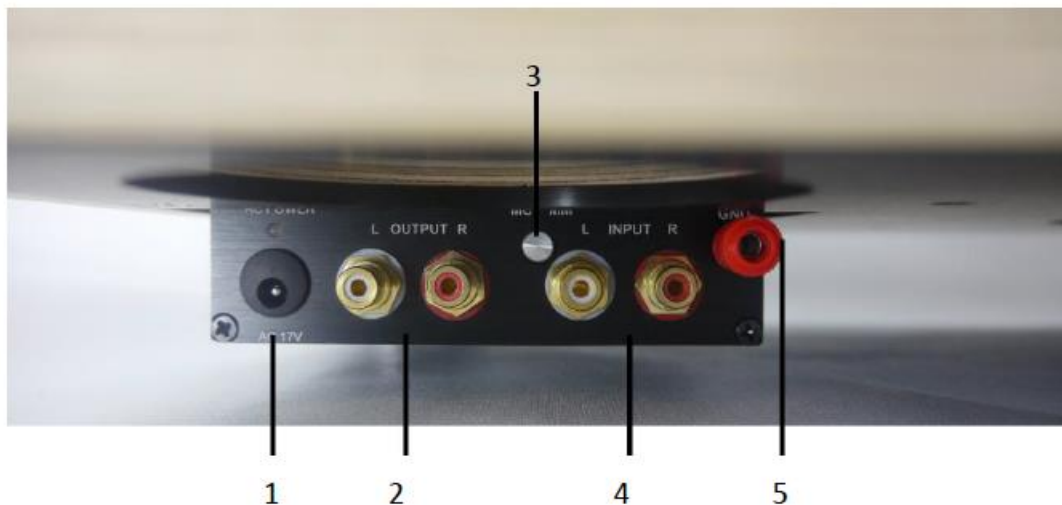

1. Phono amplifier power input (AC17V*)
2. Phono amplifier output
3. MM/MC switch
4. Phono amplifier input
5. Phono amplifier ground

* In certain market, 18V AC power supply is included instead of 17VAC

LP-18s Record Player



Adjustment and playback

1. Connect the turntable motor power supply (DC24V) and the phono amplifier power supply (AC18V). Connect the audio output of the tonearm to the input of the phono amplifier. The pickup selector switch to the MM type (for standard AT-95E cartridge), and the output of the phono amplifier to the inputs of pre-amplifier or integrated amplifier. During connection, please ensure all amplifier are power off. Turn the speed controller power on, the 33.3rpm indicator on the panel will light up, the turntable will start to rotate, press the speedometer display button, the exact value of the real-time speed will appear on the display. Adjust the fine-tuning knob on the speed controller to the appropriate speed according to the record requirements. Repeat the adjustment for 45rpm. Please note that for playing 45rpm records, start the motor in 33rpm mode first, and then switch to 45rpm mode afterwards, please do not start in 45rpm mode directly.
- 2a. VTA adjustment: put the stylus on a stationary platter, and adjust the VTA adjustment screw until the tonearm is parallel with the platter.
 - b. Stylus tracking force adjustment: put the stylus tracking force gauge on the stationary turntable, adjust the front and rear position of the counterweight, so that the reading meets the tracking force specification of the cartridge. 2.0g is recommended for standard AT-95E cartridge.
 - c. Adjust Zenith angle: with Amari's unique protractor disc, the stylus should be in line with the lines on the disc when the tip of the stylus is resting on the null points. Loosen the cartridge mounting screws, adjust the position of the cartridge and then tightening the mounting screws. Do not over-tighten the mounting screws as this may damage the phono cartridge.

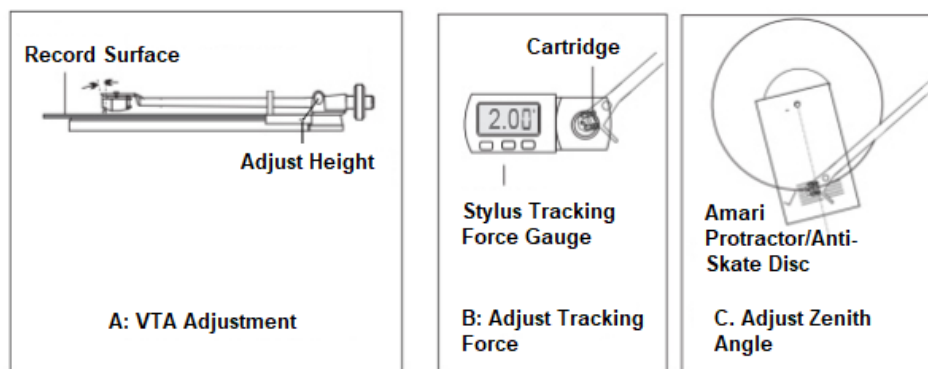

3. When the above adjustment is completed, put on the record, turn on the power of the turntable, lift the arm lift lever, move the pickup to the place where you want to start playing, slowly lower the lifter by about 20°, so that the tonearm follows the bracket and slowly lowers the stylus onto the record. At this point, you can concentrate on the music that Amari brings to you.

LP-18s Record Player



About LP-18s

The plinth

- (1) 60mm thick multi-layer wood plinth which absorbs vibration.
- (2) The bearing, motor, tonearm and feet are all fixed on 60mm thick multi layer wood plinth. The top of the plinth uses 5052 aluminum plate for cosmetic purpose.
- (3) The bottom of the multilayer board is inlaid with 4mm hot-rolled steel plate, which reduces the center of gravity of the turntable and absorbs vibration.

Magnetic levitated bearing system

- (1) Use the Neodymium Iron Boron magnet to float the bearing shaft. Adjust the lower sleeve so platter has about 1000 grams of force to press against the steel ball.
- (2) Seal oil well in the lower sleeve in order to form an oil pool around the steel ball. The steel ball and the ceramic shaft are submerged inside the oil pool, so an oil film is form on the ceramic bearing shaft. Therefore the bearing rotation is smooth, and without noise.
- (3) Bearing shaft is made of zirconia ceramics which is smooth, hard and wear-resistant.
- (4) Lower sleeve is made of copper is covered with an oil-containing copper sleeve, and special powder is sintered with copper.
- (5) The magnetic levitated bearing uses a magnetic leakage prevention mechanism to prevent magnetic leakage.
- (6) The pressure of the steel ball can be adjusted by the large nut of the lower sleeve, so that the sound can be adjusted.

Motor

- (1) Special synchronous single-phase 12-volt motor, 3w. The speed is stable, the noise is low, and the vibration is small.
- (2) Motor mechanism is mounted by an O-rings to reduce motor vibration to be transmitted to the plinth

Motor Speed Controller

Motor speed is controlled via variable frequency speed controller.

Speed Adjustment

33 1/3, 45 rpm speed controlled by electronic speed controller, and speed can be fine-tuned respectively.

Speed Monitoring

Accurate real-time infrared speed monitoring.

Feet

- (1) Three feet design for full adjustability and leveling capability.
- (2) The air suspension capsule feet has excellent shock absorption.

MM/MC Phono Amplifier

Switchable MM and MC phono amplifier.

Tonearm and Cartridge

Single point 9 inches tonearm and Audio Technica original AT-95E MM cartridge fitted as standard

Cover

One piece moulded transparent acrylic cover.

Accessories

- (1) Additional tonearm counterweight
- (2) Protractor disc
- (3) Record clamp
- (4) Stylus tracking force gauge
- (5) Bearing oil in syringe
- (6) 24V DC Power Supply
- (7) 17V AC (18V is fitted in some markets) Power Supply

Specifications

- (1) Net weight: 16.5kg
- (2) Dimensions: 460x360x200mm
- (3) Platter weight: 2.6kg
- (4) Pivot to spindle distance: 222mm
- (5) Overhang: 17.3mm

(6) Tonearm effective length: 239.3mm

(7) AT-95E tracking force: 1.5g-2.5g

(8) Phono Amplifier Input Impedance: MC 200 Ohms, MM 47K Ohms